

PHVB

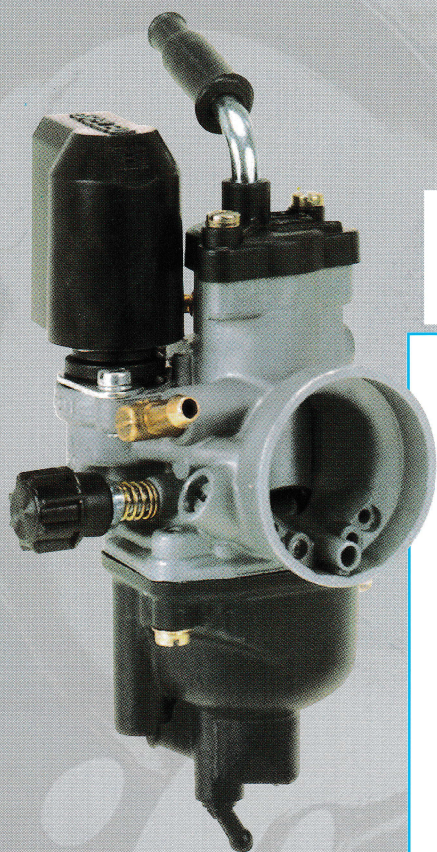

CARATTERISTICHE TECNICHE PRINCIPALI

- Diffusore: Ø19 - 20,5 - 22
- Per motori 2 tempi
- Valvola gas cilindrica
- Dispositivo avviamento a circuito indipendente con comando elettrico o manuale
- Sistema del minimo con getto e vite regolazione aria
- Sistema del massimo con regolazione meccanica della miscela a mezzo spillo conico
- Attacco: elastico Ø 29
- Attacco presa aria Ø 39,5

MAIN TECHNICAL FEATURES

- Choke: Ø19 - 20,5 - 22
- 2 stroke
- Piston type throttle valve
- Independent electric starting circuit or manual
- Idling system with jet and air adjusting screw
- Main circuit with mechanical mixture adjustment by means of conical needle
- Either Ø 29 elastic fitting connection
- Air intake connection Ø 39,5

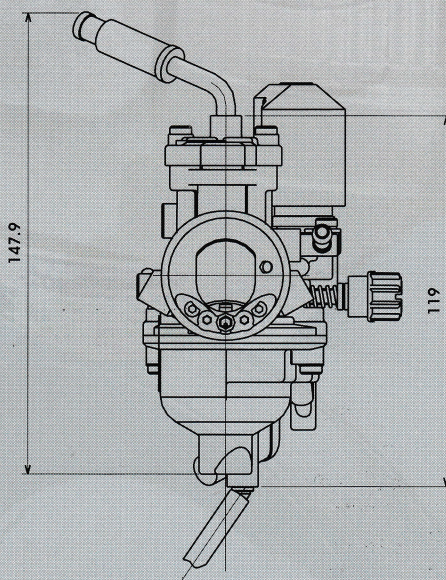
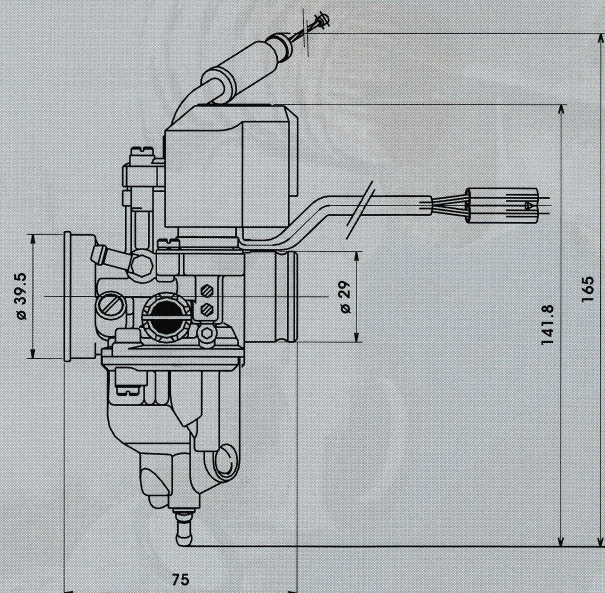
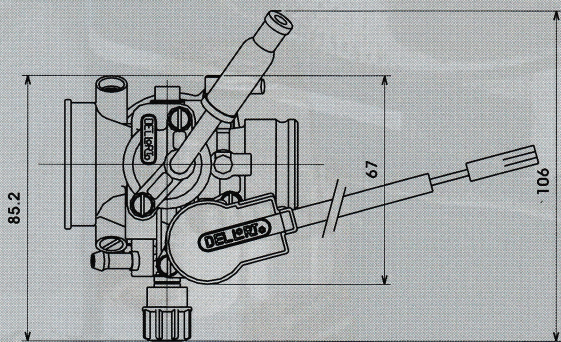
DELL'ORTO

 DELL'ORTO S.p.A. • Via S. Rocco, 5
 20038 Seregno (MI) - Italy

Tel. +39 0362 2671 - Fax +39 0362 237654

E-mail: staff@dellorto.it - www.dellorto.it