

FILTER KING

fuel device for true fuel savings and perfect fuel filtering



The new fuel pressure regulator «FILTER KING» has been specially designed to provide a constant and steady flow of fuel under all driving circumstances. The special advantage is that the «FILTER KING» compensates by means of its large and easily reacting membrane the differences of climate and altitude. It can develop a pressure up to 5 times as much as necessary to provide the carburetor with the necessary quantity of fuel. The carburetor will be overcharged there will be waste of fuel, stalling or starvation of the engine.

The «FILTER KING» has to avoid these difficulties as it is reducing and normalizing the fuel pressure. This pressure regulation grants at the same time perfect idling and immediate starting. Furthermore the elasticity of the car will be improved without lowering the performance of the engine at high revolutions. The setting of the «FILTER KING» has been exactly calculated according to engine power plus additional safety margin.

THE «FILTER KING»

**REGULATES THE PULSATION OF THE FUEL PUMP,
PREVENTS UNPLEASANT AIR BUBBLES,
REDUCES THE FORMATION OF CARBON RESIDUES,
DIMINISHES THE DANGER OF FIRE IN THE CAR,
IMPROVES THE PERFORMANCE OF THE ENGINE,
ENABLES FUEL SAVINGS FROM 5 - 10 %,
GIVES REGULAR AND CONSTANT IDLING,
MAKES EASIER DRIVING IN LONG QUEUES,
PREVENTS OVERFLOWING OF CARBURETTOR,
FILTERS WITH HIGH FILTER CAPACITY**

The «FILTER KING» has been adjusted for pressure corresponding to the top performance of the relative engine. The fuel-flow has been calculated by taking into consideration the diameter of the float needle valve and the capacity of the float bowl of the carburettor. If it should prove necessary to alter the fuel pressure to the carburettor, act as follows:

If the fuel pressure is too low take off the blind cap nut, loosen the opposite lock nut and turn the adjusting screw half a turn in clockwise direction.

If however the pressure should be too high act as before but turn the adjusting screw counterclockwise always only for half a turn. This adjustment has to be done gradually until the ideal pressure will be reached. If there should be stalling or starvation under acceleration, or at high speeds, the pressure always has to be increased by turning the adjusting screw gradually by half a turn in clockwise direction. When the setting of the screw is made, be sure to tighten the lock nut carefully, so that the position of the adjustment screw is not changed, then install cap nut and tighten.

The «FILTER KING» is warranted for perfect function. It is made under control of the best of materials and workmanship and will perform, giving benefits of economy and performance for many years of trouble-free-service.

Model of function FILTER KING

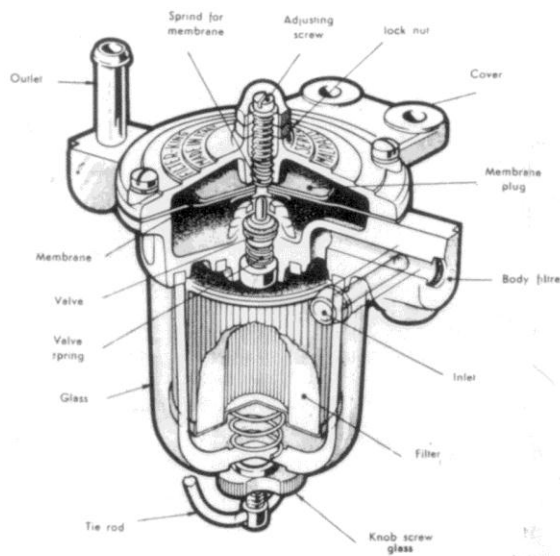

Approved by
automotive engineers
and carburettor
specialists

IMPORTANT

Before mounting, be sure that the engine is in perfect condition. Check the ignition system, contacts and the spark plugs. These parts are necessary for the engine to reach its top performance.

The « FILTER KING » has to be installed on the car-body at distance of all sources of warmth and engine vibrations. For installation use the special support delivered together with the « FILTER KING », care for horizontal mounting. After having installed the « FILTER KING » make sure that there will be no leakage between the fuel pump and the carburettor, fastening the pipe to the inlet and outlet adapters by the safety-clamps.

Check the idling and eventually adjust it.

